

Theia SY110M

SY110M envelope Theia Technologies

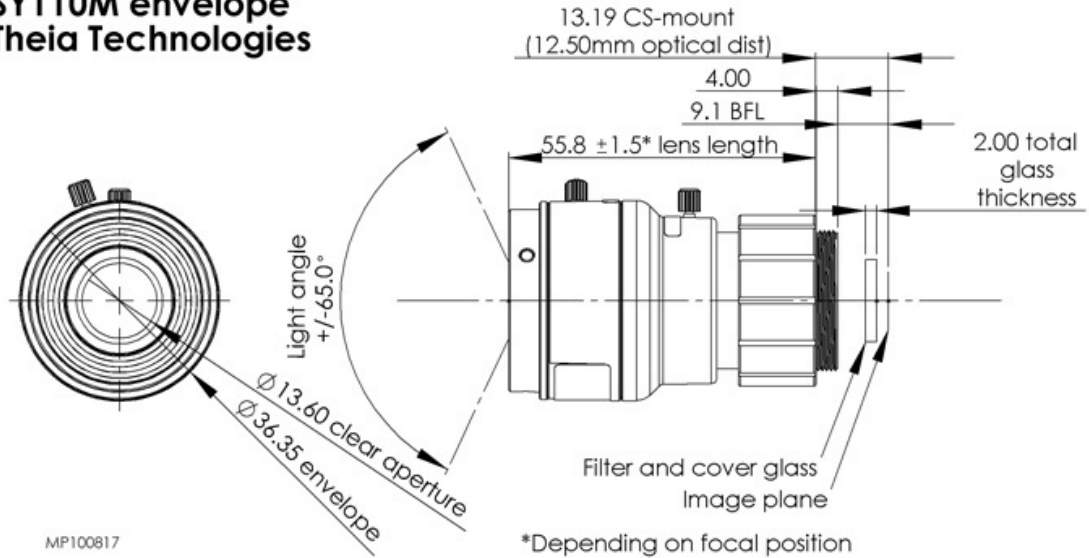

The CS-Mount lens Theia SY110M is suitable for common sensors up to 3 megapixel with an image format of 1/2.5 inch. It is characterized by a particularly high light intensity.

Technical Data

Mount	CS-Mount
Sensor	1/2.5 inch
Focal Length	1.7 mm
Aperture	1.8
MOD	0.5 m
Back Focal	9.1 mm
Angle of View	D:130° H:120° V:104°
Megapixel	3 MP
IR Correction	Yes
IR Cut Filter	No
Weight	47 g
Iris	manual-lock
Focus	manual-lock
Typ	No Distortion



Light Sensitive



3 Megapixel