

Lensagon ST05

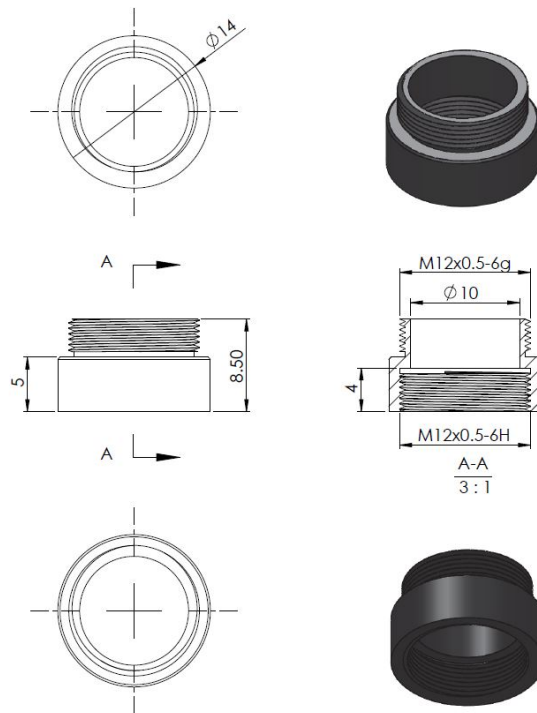

M12 extension ring 5 mm, anodized

Technical Data

AC Type	Extension
Material	Aluminum
Height	815 mm
Width	641 mm
Color	Black
Weight	0.8 g

