

# BM8021S118ND

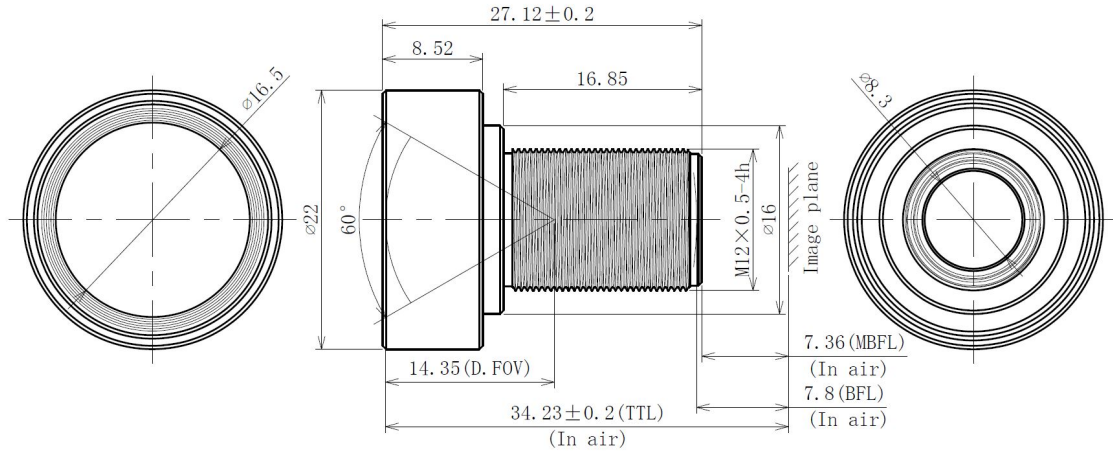

The S-Mount lens Lensagon BM8021S118ND is suitable for common sensors up to 1 megapixel with an image format of 1/1.8 inch.

## Technical Data

Mount	S-Mount
Sensor	1/1.8 - 1/2 inch Sensor
Focal Length	7.84 mm
Aperture	2.1
MOD	0.5 m
Back Focal	7.8 mm
Angle of View	D:60° H:53.3° V:31.1°
Megapixel	1-2 MP
IR Correction	Yes
Optical Distortion	-2.9 %
Image Circle	9 mm
Iris	fixed
Focus	fixed
Chief ray angle	8.7 °

1

Megapixel

