

Lensagon BM8020S12

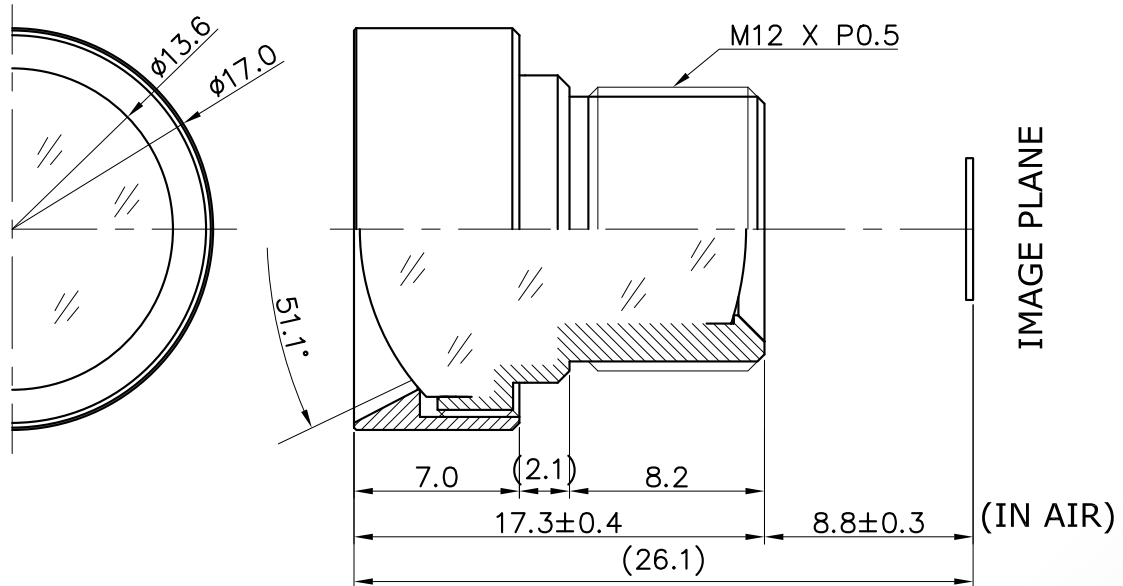

The S-Mount lens Lensagon BM8020S12 is suitable for common sensors up to 1 megapixel with an image format of 1/2 inch. It is characterized by a particularly high light intensity.

Technical Data

Mount	S-Mount
Sensor	1/2 inch
Focal Length	8 mm
Aperture	2
MOD	1 m
Back Focal	8.7 mm
Angle of View	D:51.1° H:46.8° V:42.1°
Megapixel	1-2 MP
IR Cut Filter	No
Weight	7.1 g
Iris	fixed
Focus	fixed
Typ	Standard



Light Sensitive



1 Megapixel