

Lensagon B5M8018C

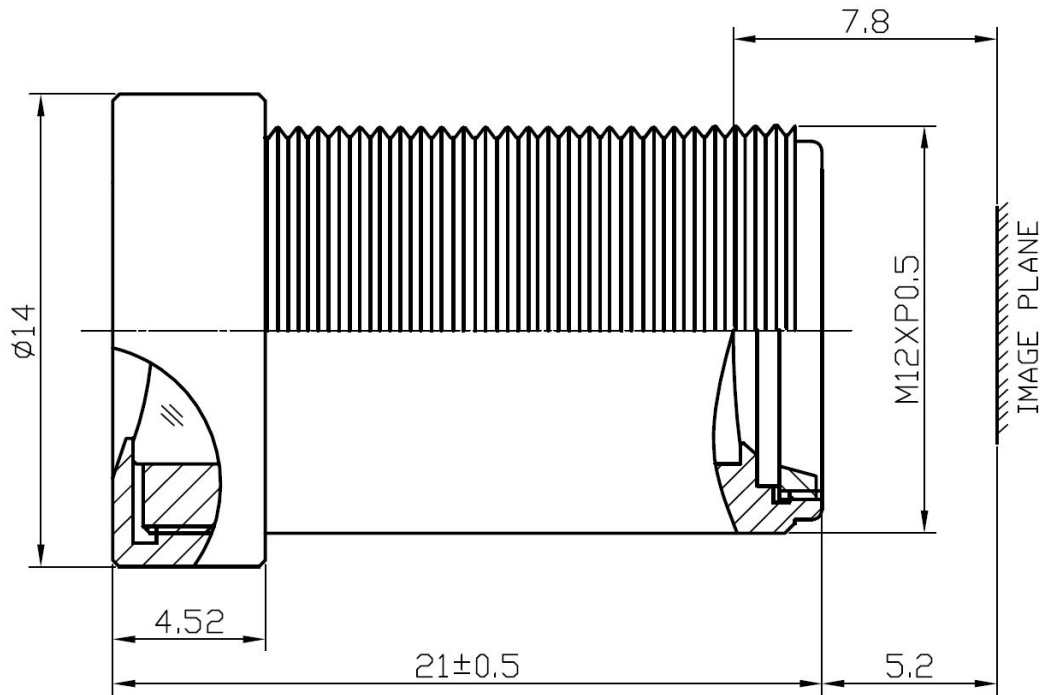

The S-Mount lens Lensagon B5M8018C is suitable for common sensors up to 5 megapixel with an image format of 1/2.5 inch. It is characterized by a particularly high light intensity.

Technical Data

Mount	S-Mount
Sensor	1/2.5 inch
Focal Length	8 mm
Aperture	1.8
MOD	0.5 m
Back Focal	7.8 mm
Angle of View	D:52.1° H:41.4° V:30.8°
Megapixel	5 MP
IR Correction	No
IR Cut Filter	Yes
Weight	6.4 g
Iris	fixed
Focus	fixed
Typ	Standard



Light Sensitive



5 Megapixel