

B3M35025V2

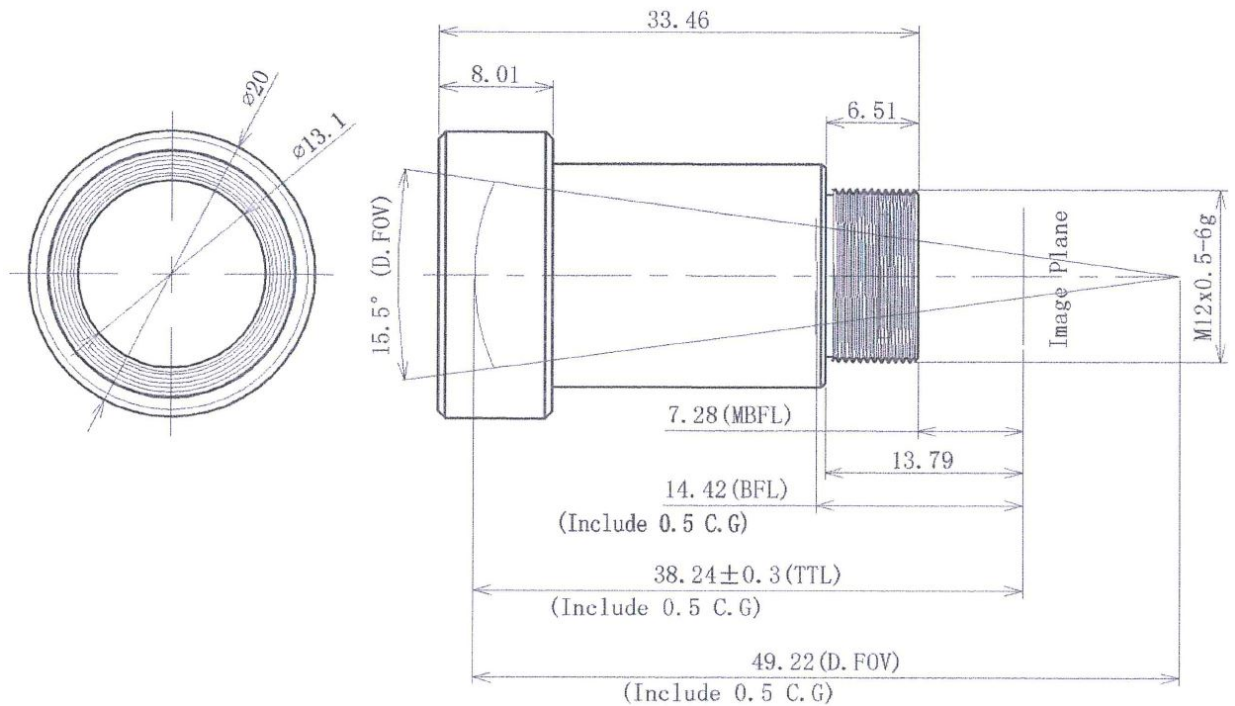

The S-Mount lens Lensagon B3M35025V2 is suitable for common sensors up to 3 megapixel with an image format of 1/1.7 inch.

Technical Data

Mount	S-Mount
Sensor	1/1.7 inch
Focal Length	35 mm
Aperture	2.8
MOD	0.5 m
Back Focal	14.42 mm
Angle of View	D:15.5° H:12.4° V:9.3°
Megapixel	3 MP
IR Correction	No
Optical Distortion	0.1 %
Image Circle	9.6 mm
Iris	fixed
Focus	fixed
Chief ray angle	10 °
Typ	Standard



3 Megapixel