

B2M10030N2C

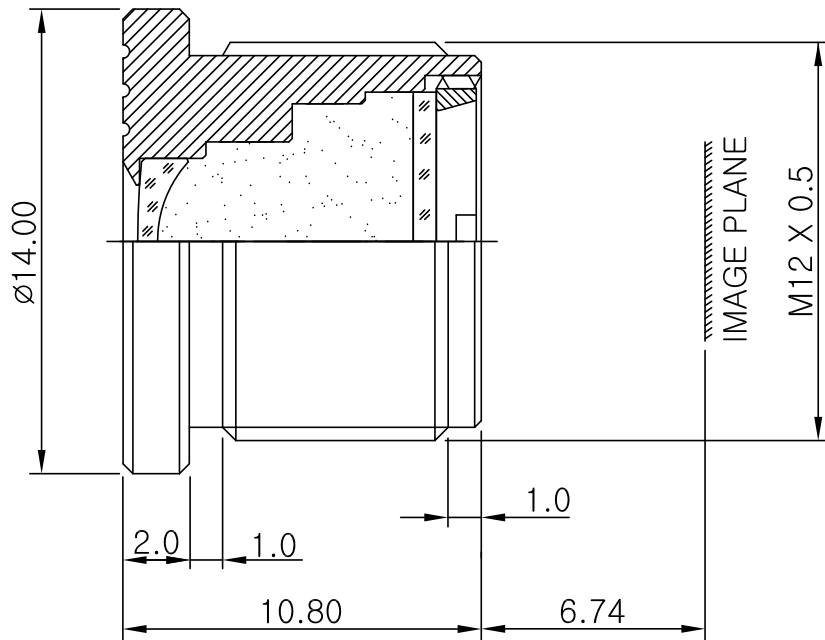

Tolerance : $\pm 0.4\text{mm}$

The S-Mount lens Lensagon B2M10030N2C is suitable for common sensors up to 2 megapixel with an image format of 1/2 inch.

Technical Data

Mount	S-Mount
Sensor	1/2 inch
Focal Length	10.3 mm
Aperture	3
MOD	0.2 m
Back Focal	8.77 mm
Angle of View	D:41.5° H:33° V:25°
Megapixel	2 MP
IR Correction	No
IR Cut Filter	Yes
Optical Distortion	2.1 %
Weight	3.7 g
Iris	fixed
Focus	fixed
Typ	Standard

